

## A Reinvestigation of the Crystal Structure of Potassium Hydrogen Di-*p*-hydroxybenzoate Hydrate

BY LJUBICA MANOJLOVIĆ\*

*Chemistry Department, University of Glasgow, Glasgow, W.2, Scotland*

(Received 30 May 1967)

The crystal structure of potassium hydrogen di-*p*-hydroxybenzoate hydrate,  $\text{KH}(\text{C}_7\text{H}_5\text{O}_3)_2 \cdot \text{H}_2\text{O}$ , has been redetermined by three-dimensional X-ray methods. The final value of  $R$  is 8.1% for 1264 photographically estimated intensities. The coordination of the potassium ion, the structure of the *p*-hydroxybenzoic acid residue and the system of intermolecular OHO bonds are discussed. The length of the very short, and crystallographically symmetrical hydrogen bond, characteristic of type *A* acid salts, is found to be  $2.458 \pm 0.006 \text{ \AA}$ .

### Introduction

The crystal structure of potassium hydrogen di-*p*-hydroxybenzoate hydrate,  $\text{KHX}_2 \cdot \text{H}_2\text{O}$  ( $\text{HX} = p$ -hydroxybenzoic acid,  $\text{HO} \cdot \text{C}_6\text{H}_4 \cdot \text{CO}_2\text{H}$ ), was solved by Skinner & Speakman (1951) in two projections. The compound proved to be a type *A* acid salt (Shrivastava & Speakman, 1961). It contains a crystallographically symmetrical OHO bond, formed by two carboxyl groups and suspected to possess genuine symmetry (Speakman, 1967). Skinner & Speakman's value of  $2.61 \text{ \AA}$  for the length of this bond is higher than those found hitherto in the other type *A* acid salts, and is much higher than expected for a truly symmetrical OHO bond; it led Rundle (1964) to question the results of the spectroscopic studies of this compound (Blinic, Hadži & Novak, 1960). Since the accuracy of Skinner & Speakman's analysis was rather low ( $R_{h0l} = 17.9\%$ ,  $R_{hk0} = 24.9\%$ ), a reinvestigation of the structure by three-dimensional X-ray methods was undertaken at Dr Speakman's suggestion.

### Crystal data

$\text{KH}(\text{C}_7\text{H}_5\text{O}_3)_2 \cdot \text{H}_2\text{O}$ , or  $\text{C}_{14}\text{H}_{11}\text{KO}_6 \cdot \text{H}_2\text{O}$ .  $M = 332.4$ . Monoclinic,  $a = 16.50 \pm 0.01$ ,  $b = 3.846 \pm 0.005$ ,  $c = 11.20 \pm 0.01 \text{ \AA}$ ,  $\beta = 92.8 \pm 0.2^\circ$  ( $\lambda(\text{Cu } K\alpha_1) = 1.5405 \text{ \AA}$ ).  $V = 709.9 \text{ \AA}^3$ ,  $D_m$  (Skinner & Speakman, 1951) =  $1.54$ – $1.55 \text{ g.cm}^{-3}$ ,  $Z = 2$ ,  $D_c = 1.555 \text{ g.cm}^{-3}$ .  $F(000) = 344$ ,  $\mu(\text{Mo } K\alpha) = 4.1 \text{ cm}^{-1}$ . Space group  $P2/c$  (no. 13).

### Experimental

Crystals of  $\text{KHX}_2 \cdot \text{H}_2\text{O}$ , supplied by Dr Speakman, were transparent plates elongated along **b**. Two pieces,

cut to needle shape, and of diameters  $\sim 0.20 \text{ mm}$  and  $0.25 \text{ mm}$  ( $\mu R = 0.08$  and  $0.10$ ), were used in this analysis.

Unit-cell dimensions cited above were derived by least-squares refinement of  $\sin \theta$  values for high order reflexions; the angles  $\theta$  were measured from equatorial Weissenberg photographs, taken about **b** and **c** with  $\text{Cu } K\alpha$  radiation, and calibrated with powder lines from a thin aluminum wire. The dimensions obtained are in fair agreement with the ones reported by Skinner & Speakman (1951):  $a = 16.40 \pm 0.05$ ,  $b = 3.82 \pm 0.02$ ,  $c = 11.30 \pm 0.03 \text{ \AA}$  and  $\beta = 92.5 \pm 0.5^\circ$ .

The intensities of 1264 independent reflexions were estimated visually from equi-inclination Weissenberg photographs of the  $h0l$  to  $h3l$  and  $hk0$  reciprocal lattice nets. The photographs were taken with  $\text{Mo } K\alpha$  radiation. Reflexions too weak to be observed were not included in the analysis. Lorentz and polarization factors were applied, but no correction for absorption was made. The structure amplitudes on different reciprocal lattice nets were brought to the same scale by comparison of the common reflexions.

### Refinement

The structure was refined by full-matrix least squares, using the structure factor – least squares program of J. G. F. Smith and D. W. J. Cruickshank for the KDF9 computer. The atomic scattering factors for the heavier atoms were taken from *International Tables for X-ray Crystallography* (1962); for hydrogen atoms the scattering curve of Stewart, Davidson & Simpson (1965) was used. Cruickshank's weighting scheme, with

$$w = 1/(4.5 + |F_o| + 0.021|F_o|^2),$$

was found satisfactory.

Refinement was started with the atomic coordinates of Skinner & Speakman (1951) and arbitrarily chosen isotropic vibrational parameters. Three cycles of refinement of these parameters and of an overall scale factor reduced  $R$  from 50% to 17.7%. In the following

\* On leave of absence from Institute of Nuclear Sciences 'Boris Kidrič', Vinča-Belgrade, P.O. Box 522, Yugoslavia. Present address: Chemistry Department, Brookhaven National Laboratory, Upton, L. I., N. Y. 11973, U.S.A.

Table 1. *Analysis of the agreement of observed and calculated structure factors at the end of refinement*

(a) as a function of the magnitude of observed structure factors

$ F_o $ range	$\Sigma F_o $	$\Sigma F_c $	$\Sigma \Delta $	$N$	$R$	$\Sigma \Delta /N$
0-5	1782.9	1759.3	377.2	565	0.212	0.67
5-10	2627.5	2596.8	219.8	366	0.084	0.60
10-15	1978.9	1955.5	141.5	163	0.072	0.87
15-20	1028.2	1012.1	68.2	60	0.066	1.14
20-30	1452.3	1450.9	73.4	61	0.051	1.20
30-40	937.9	950.0	36.7	28	0.039	1.31
40-50	880.7	872.9	53.4	18	0.061	2.97
60-85	145.8	153.0	7.2	2	0.050	3.61

(b) as a function of the layer line index

$k$	$\Sigma F_o $	$\Sigma F_c $	$\Sigma \Delta $	$N$	$R$	$\Sigma \Delta /N$
0	3365.7	3282.6	246.3	217	0.073	1.14
1	3910.6	3832.4	273.6	398	0.070	0.69
2	2352.3	2424.7	235.3	363	0.100	0.65
3	1296.9	1211.2	130.7	286	0.101	0.46
all	10925.5	10750.9	885.9	1264	0.081	0.70

$|F_o|$  and  $|F_c|$  are on the absolute scale.  
 $N$  = number of reflexions.

two cycles anisotropic vibrational parameters were introduced and  $R$  decreased to 10.1%.

A difference synthesis based on terms with  $\sin \theta/\lambda < 0.355 \text{ \AA}^{-1}$ , was then computed. The five peaks higher than  $0.24 \text{ e.\AA}^{-3}$  corresponded to the expected positions of the acidic and benzenoid hydrogen atoms. Accordingly, these hydrogen atoms were included in subse-

quent structure factor calculations, but in calculated positions and with isotropic vibrational parameters 1.5 times that of the atoms to which they are bonded. As a result  $R$  decreased by 0.8%.

The refinement converged after three further cycles, in which the scale factor and the positional and anisotropic vibrational parameters of all atoms, except hydrogen, were adjusted. In the final cycle parameter shifts were less than 0.1 of the corresponding e.s.d.'s. The final  $R$  value was 8.1%.

Observed structure amplitudes and calculated structure factors are stored on a magnetic tape at Glasgow University, and can be obtained from Dr J. G. Sime by quoting the reference number GL/1967/3. An analysis of the agreement of observed and calculated structure factors at the end of refinement is presented in Table 1. The final coordinates and vibrational parameters of the heavier atoms, with corresponding standard deviations (e.s.d.'s) estimated from the full normal matrix, are listed in Tables 2 and 3. The parameters of the hydrogen atoms are given in Table 4. The numbering of atoms in the asymmetric unit is shown in Fig. 1.

Table 2. *Fractional atomic coordinates and e.s.d.'s*

	$x$	$y$	$z$
K	0.00000	-0.3206 (5)	0.25000
O(W)	0.50000	-0.0442 (23)	-0.25000
O(2)	0.06806 (18)	0.0497 (13)	-0.03652 (28)
O(3)	0.09826 (20)	0.2058 (12)	0.15109 (29)
O(4)	0.44339 (21)	0.3545 (16)	-0.07484 (42)
C(1)	0.11771 (24)	0.1549 (15)	0.04773 (39)
C(2)	0.20356 (22)	0.2136 (13)	0.01299 (36)
C(3)	0.22932 (23)	0.1070 (14)	-0.09738 (38)
C(4)	0.30952 (24)	0.1527 (16)	-0.12691 (40)
C(5)	0.36369 (25)	0.3078 (17)	-0.04488 (45)
C(6)	0.33843 (25)	0.4187 (16)	0.06589 (41)
C(7)	0.25814 (26)	0.3715 (15)	0.09384 (39)

Table 3. *Vibration tensor components and e.s.d.'s ( $\text{\AA}^2$ )*

	$U_{11}$	$U_{22}$	$U_{33}$	$2U_{23}$	$2U_{31}$	$2U_{12}$
K	0.0501 (09)	0.0664 (14)	0.0437 (09)	0.0000	0.0356 (13)	0.0000
O(W)	0.0676 (38)	0.0967 (58)	0.0723 (40)	0.0000	0.0186 (60)	0.0000
O(2)	0.0265 (13)	0.1088 (35)	0.0363 (18)	-0.0033 (35)	0.0042 (23)	-0.0161 (34)
O(3)	0.0401 (16)	0.0829 (30)	0.0366 (17)	-0.0117 (32)	0.0270 (26)	-0.0138 (33)
O(4)	0.0312 (17)	0.1183 (44)	0.0844 (30)	-0.0477 (54)	0.0373 (36)	-0.0443 (41)
C(1)	0.0274 (18)	0.0621 (35)	0.0362 (21)	0.0017 (39)	0.0128 (30)	-0.0021 (37)
C(2)	0.0235 (16)	0.0523 (31)	0.0335 (20)	0.0072 (34)	0.0053 (27)	-0.0029 (32)
C(3)	0.0251 (17)	0.0624 (34)	0.0347 (21)	0.0021 (38)	-0.0016 (28)	-0.0084 (35)
C(4)	0.0266 (17)	0.0722 (39)	0.0387 (23)	0.0000 (41)	0.0120 (31)	-0.0137 (39)
C(5)	0.0252 (17)	0.0770 (41)	0.0479 (25)	0.0011 (47)	0.0150 (33)	-0.0120 (40)
C(6)	0.0278 (19)	0.0696 (38)	0.0423 (24)	-0.0101 (42)	-0.0079 (32)	-0.0160 (39)
C(7)	0.0331 (19)	0.0636 (36)	0.0334 (21)	-0.0059 (39)	0.0050 (31)	0.0010 (39)

Table 4. *Hydrogen atom parameters*

	<i>x</i>	<i>y</i>	<i>z</i>	<i>U</i>
H(2)	0.0000	0.000	0.0000	0.065 Å <sup>2</sup>
H(3)	0.1860	-0.012	-0.1626	0.053
H(4)	0.3291	0.071	-0.2137	0.057
H(6)	0.3817	0.539	0.1306	0.060
H(7)	0.2381	0.454	0.1802	0.057

H(2) belongs to the carboxyl group. The remaining hydrogen atoms are marked with the same numbers as the C atoms to which they are bonded.

### Discussion

The crystal structure is essentially the same as that described by Skinner & Speakman (1951). Layers of *p*-hydroxybenzoic acid residues, parallel to (100), are linked together by a system of OHO bonds and by strong electrovalent forces between the potassium ion and the oxygen atoms of the carboxyl groups (Fig. 1).

This analysis has produced shifts of up to 0.29 Å from the atomic coordinates reported by Skinner & Speakman (1951).

#### The coordination of the potassium ion

The potassium ion lies on a twofold axis and is surrounded by a distorted octahedron of oxygen atoms from six different carboxyl groups. The interatomic distances and angles in the coordination octahedron are listed in Table 5. The K...O distances are in a good agreement with the corresponding ones of 2.718, 2.801 and 2.855 Å in potassium hydrogen bisphenylacetate (Manojlović & Speakman, 1968).

Table 5. *Interatomic distances and angles in the coordination octahedron around the potassium ion*

K...O(3 <sup>iv</sup> )	2.711 (4) Å
K...O(2 <sup>i</sup> )	2.793 (4)
K...O(3)	2.852 (4)
O(3 <sup>iv</sup> )...K...O(2 <sup>i</sup> )	97.1°
O(3 <sup>iv</sup> )...K...O(2 <sup>ii</sup> )	112.2
O(3 <sup>iv</sup> )...K...O(3 <sup>iii</sup> )	177.0
O(3 <sup>iv</sup> )...K...O(3)	87.5
O(2 <sup>i</sup> )...K...O(2 <sup>ii</sup> )	136.2
O(2 <sup>i</sup> )...K...O(3 <sup>iii</sup> )	81.7
O(2 <sup>i</sup> )...K...O(3)	67.4
O(3 <sup>iii</sup> )...K...O(3)	89.5
O(3 <sup>v</sup> )...K...O(3 <sup>iv</sup> )	95.6

Superscripts refer to atoms at:

CCU	<i>x</i>	<i>y</i>	<i>z</i>
i	$\bar{x}$	$\bar{y}$	$\bar{z}$
ii	$x$	$\bar{y}, \frac{1}{2} + z$	
iii	$\bar{x}$	$y, \frac{1}{2} - z$	
iv	$x$	$-1 + y$	$z$
v	$\bar{x}$	$-1 + y, \frac{1}{2} - z$	
vi	$1 - x$	$1 - y$	$\bar{z}$
vii	$x$	$1 + y$	$z$

#### The structure of the *p*-hydroxybenzoic acid residue

The two organic acid residues of the stoichiometric unit are crystallographically identical, as in the other type *A* acid salts. The atoms of each organic residue

are distributed in two planes. The mean plane of the benzenoid ring is defined by the equation

$$-0.2333X' + 0.8961Y - 0.3775Z' = -0.0341 \text{ \AA},$$

where  $X' = ax \sin \beta$ ,  $Y = by$  and  $Z' = ax \cos \beta + cz$ . The r.m.s. deviation of the atoms from the plane is 0.003 Å. Atom O(4) is displaced from this plane by only 0.003 Å. The mean plane of the carboxyl group and C(2) is represented by the equation

$$-0.2239X' + 0.9493Y - 0.2208Z' = 0.0331 \text{ \AA},$$

and the r.m.s. deviation of the atoms from the plane is 0.0005 Å. The dihedral angle between the two planes is 9.5°.

Bond lengths and angles in the *p*-hydroxybenzoic acid residue are presented in Table 6. The main difference from the corresponding results of Skinner & Speakman's (1951) analysis is in the increase of bond lengths C(3)-C(4), C(6)-C(7) and C(5)-O(4) by 0.071, 0.078 and 0.045 Å, respectively. The C-C distances in the benzene ring now range from 1.385 to 1.395 Å; their mean of 1.389 Å is in agreement with 1.392 Å found in crystalline benzene (Cox, Cruickshank & Smith, 1958). The length of the phenolic C(5)-O(4) bond of 1.385 Å is comparable with 1.372 and 1.393 Å recently obtained in unsubstituted dihydroxybenzenes, catechol (Brown, 1966) and  $\gamma$ -hydroquinone (Maartmann-Moe, 1966); it is longer than the C-O distances of 1.361, 1.358 and 1.351 Å, respectively found in the phenols with electron-withdrawing substituents,  $\beta$ -*p*-nitrophenol (Coppens & Schmidt, 1965a), salicylic acid

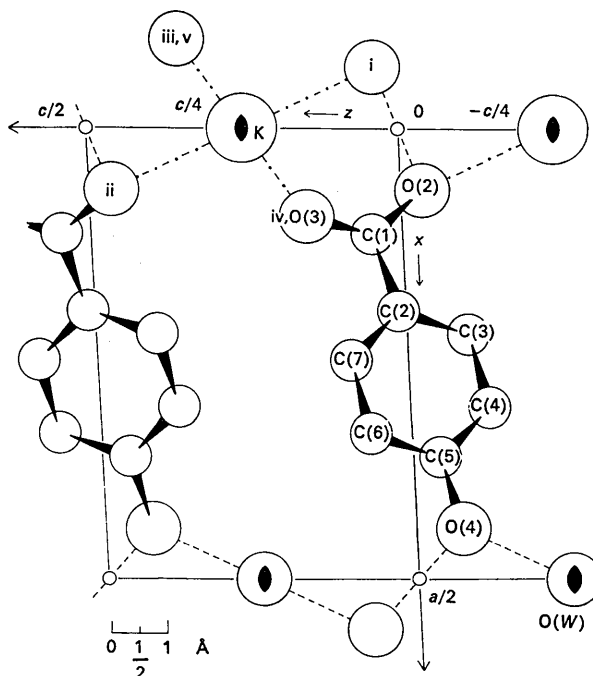

Fig. 1. The (010) projection of the structure, showing the numbering of atoms in the crystal-chemical unit. The significance of the Roman numerals is the same as in Table 5.

(Sundaralingam & Jensen, 1965) and  $\alpha$ -*p*-nitrophenol (Coppens & Schmidt, 1965*b*). The C(1)–C(2) bond of 1.504 Å agrees well with the value of 1.505 Å given by Sutton (1965). All the anomalies in the bond lengths

Table 6. Bond lengths and angles, with corresponding e.s.d.'s, in the *p*-hydroxybenzoic acid residue

Bonds	
O(2)–C(1)	1.284 (6) Å
O(3)–C(1)	1.232 (5)
O(4)–C(5)	1.385 (6)
C(1)–C(2)	1.504 (6)
C(2)–C(3)	1.389 (6)
C(3)–C(4)	1.391 (6)
C(4)–C(5)	1.385 (7)
C(5)–C(6)	1.395 (7)
C(6)–C(7)	1.388 (6)
C(7)–C(2)	1.386 (6)
Angles	
O(2)–C(1)–O(3)	123.7 (4)°
O(2)–C(1)–C(2)	115.6 (4)
O(3)–C(1)–C(2)	120.7 (4)
C(1)–C(2)–C(3)	121.3 (4)
C(1)–C(2)–C(7)	119.1 (4)
C(3)–C(2)–C(7)	119.6 (4)
C(2)–C(3)–C(4)	120.7 (4)
C(3)–C(4)–C(5)	119.2 (4)
C(4)–C(5)–C(6)	120.7 (4)
C(4)–C(5)–O(4)	119.0 (5)
C(6)–C(5)–O(4)	120.3 (5)
C(5)–C(6)–C(7)	119.4 (4)
C(6)–C(7)–C(2)	120.5 (4)

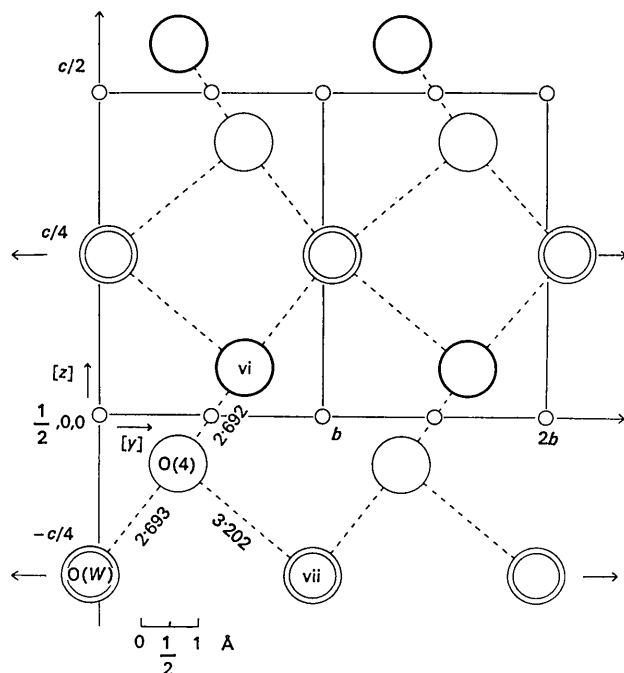

Fig. 2. The arrangement of oxygen atoms at  $x = \frac{1}{2}$ . The inter-oxygen distances shorter than 3.3 Å are shown by broken lines. The O(4) atoms drawn with thin circles are below, and the O(4) atoms drawn with thick circles are above the plane. The significance of the Roman numerals is the same as in Table 5.

of the *p*-hydroxybenzoic acid residue reported by Skinner & Speakman (1951) have, therefore, disappeared. The results of this analysis do not support their suggestion that the quinonoid structure contributes notably to the overall resonance state of the molecule.

The difference between the O(2)–C(1) and C(1)–O(3) distances of 0.052 Å is significant, and so are the deviations of the O(2)–C(1)–C(2) and O(2)–C(1)–O(3) angles from 120°. This suggests that, as in the other type *A* acid salts (Manojlović & Speakman, 1967, 1968), the carboxyl group is intermediate in character between fully ionized and neutral.

#### The hydrogen bonding

There are three crystallographically independent hydrogen atoms available for hydrogen bonding. Only one of these, the acidic hydrogen, was detected by the low-angle difference synthesis; the conclusions about hydrogen bonding are, therefore, based mainly on geometrical considerations.

The system of hydrogen bonding in this compound is different from that found in the other type *A* acid salts (Fig. 1). Besides the hydrogen bonds between carboxyl groups at  $x = 0$ , there are hydrogen bonds at  $x = \frac{1}{2}$ , formed by water molecules and the phenolic OH-groups (Fig. 2): O(4)···O(4<sup>vi</sup>) = 2.692 ± 0.009 Å, O(4)···O(W) = 2.693 ± 0.007, and perhaps also O(4)···O(W<sup>vii</sup>) = 3.202 ± 0.008 Å. However, no single arrangement of the two available hydrogen atoms (Fig. 2) can satisfy the requirements of the space group symmetry; some disorder of hydrogen atoms in this region of the structure seems, therefore, likely. This view may also be supported by the high vibrational parameters of the atoms O(W) and O(4), and by the fact that the low-angle difference synthesis gave no clear indication of the positions of the phenolic and water hydrogen atoms.

Two of the hydrogen bonds present in this compound are crystallographically symmetrical. The long one, O(4)···O(4<sup>vi</sup>), of 2.692 Å links together the phenolic groups of the two *p*-hydroxybenzoic acid residues across the centre of symmetry at  $\frac{1}{2}, \frac{1}{2}, 0$ . The angle C(5)–O(4)···O(4<sup>vi</sup>) is 122.8°. The very short, crystallographically symmetrical hydrogen bond, characteristic of all type *A* acid salts, connects the carboxyl groups of the two *p*-hydroxybenzoic acid residues across the centre of symmetry at 0, 0, 0. The angle C(1)–O(2)···O(2<sup>i</sup>) of 111.4° is such as to favour strong hydrogen bonding. Skinner & Speakman (1951) reported a value of 2.61 Å for the O(2)···O(2<sup>i</sup>) distance; this analysis leads to 2.458 ± 0.006 Å, which is in good agreement with the values found in all accurately studied type *A* acid salts.

The very short, crystallographically symmetrical hydrogen bond in type *A* acid salts is suspected to be genuinely symmetrical, with the proton in a single potential well at the midpoint (Speakman, 1967). The available spectroscopic evidence (infrared and nuclear magnetic resonance) on the hydrogen bonding in potas-

sium hydrogen di-*p*-hydroxybenzoate hydrate (Blinč, Hadži & Novak, 1960) is consistent with the above view. And so is the agreement of the O(2)···O(2<sup>1</sup>) bond length with the value of about 2.45 Å, tentatively suggested by Coulson (1957, 1959) to be the upper limit for the length of a truly symmetrical OHO bond.

The environment of the O(2)···O(2<sup>1</sup>) bond is symmetrical and also closely packed; the non-bonded distances H(2)···O(3) of 2.42 Å and H(2)···C(1) of 2.08 Å are shorter than the sum of van der Waals radii. It might be that the resulting strain is sufficient to establish symmetry within the bond itself.

It is a pleasure to thank Dr J. C. Speakman for advice and much valuable discussion. Thanks are also due to Drs J. G. Sime, K. W. Muir and W. S. McDonald for making available their crystallographic programs for the KDF9 computer. The work was supported by a grant from the British Science Research Council.

#### References

- BLINČ, R., HADŽI, D. & NOVAK, A. (1960). *Z. Elektrochem.* **64**, 567.  
 BROWN, C. J. (1966). *Acta Cryst.* **21**, 170.  
 COPPENS, P. & SCHMIDT, G. M. J. (1965*a*). *Acta Cryst.* **18**, 654.  
 COPPENS, P. & SCHMIDT, G. M. J. (1965*b*). *Acta Cryst.* **18**, 62.  
 COULSON, C. A. (1957). *Research*, **10**, 149.  
 COULSON, C. A. (1959). In *Hydrogen Bonding* (D. Hadži, Editor). London: Pergamon Press, p. 339.  
 COX, E. G., CRUICKSHANK, D. W. J. & SMITH, J. A. S. (1958). *Proc. Roy. Soc. A* **247**, 1.  
*International Tables for X-ray Crystallography* (1962). Vol. III. Birmingham: Kynoch Press.  
 MAARTMANN-MOE, K. (1966). *Acta Cryst.* **21**, 979.  
 MANOJLOVIĆ, LJ. & SPEAKMAN, J. C. (1967). *J. Chem. Soc.* p. 971.  
 MANOJLOVIĆ, LJ. & SPEAKMAN, J. C. (1968). *Acta Cryst.* **B24**, 323.  
 RUNDLE, R. E. (1964). *J. Physique*, **23**, 487.  
 SHRIVASTAVA, H. N. & SPEAKMAN, J. C. (1961). *J. Chem. Soc.* p. 1151.  
 SKINNER, J. M. & SPEAKMAN, J. C. (1951). *J. Chem. Soc.* p. 185.  
 SPEAKMAN, J. C. (1967). *Chem. Comm.* p. 32.  
 STEWART, R. F., DAVIDSON, E. R. & SIMPSON, W. T. (1965). *J. Chem. Phys.* **42**, 3175.  
 SUNDARALINGAM, M. & JENSEN, L. H. (1965). *Acta Cryst.* **18**, 1053.  
 SUTTON, L. E. (1965). *Tables of Interatomic Distances and Configuration in Molecules and Ions, Supplement*. London: The Chemical Society.

*Acta Cryst.* (1968). **B24**, 330

## The Crystal Structure of (CH<sub>3</sub>)<sub>4</sub>NNiCl<sub>3</sub>\*

BY G. D. STUCKY

*Department of Chemistry and Chemical Engineering and Materials Research Laboratory,  
University of Illinois, Urbana, Illinois 61801, U.S.A.*

(Received 22 May 1967)

The crystal structure of (CH<sub>3</sub>)<sub>4</sub>NNiCl<sub>3</sub> has been determined from three-dimensional Mo K $\alpha$  X-ray data collected by counter methods. The structure has been refined by the full-matrix least-squares technique. The material crystallizes in the space group  $P6_3/m$  ( $C_{6h}^2$ ) or  $P6_3$  ( $C_6^3$ ) of the hexagonal system, with two molecules in a unit cell of dimensions  $a=b=9.019$ ,  $c=6.109$  Å. The structure consists of linear one-dimensional chains of nickel atoms with three bridging chlorine atoms between the nickel atoms.

#### Introduction

Furlani & Morpurgo (1961) first reported the syntheses of two colored complexes, one red and one blue, from solutions of tetramethylammonium bromide and nickel bromide in nitromethane. Magnetic susceptibility measurements gave  $\mu_{\text{eff}}=3.8$  B.M. (370°K) for the blue crystals and 3.23 B.M. (299°K) for the red crystals. The elementary analyses were reported to give the

same stoichiometry, namely [(CH<sub>3</sub>)<sub>4</sub>N]<sub>2</sub>NiBr<sub>4</sub>. Both complexes dissolved in nitromethane to give blue solutions, and the red crystals could be converted to the blue crystals upon heating. It was proposed that the red and blue forms were isomers similar to the  $\alpha$  and  $\beta$  forms of CoCl<sub>2</sub>.2C<sub>5</sub>H<sub>5</sub>N (Dunitz, 1957). We have repeated Furlani & Morpurgo's synthesis and readily obtained the two forms of the crystals; however, the red modification proved to be (CH<sub>3</sub>)<sub>4</sub>NNiBr<sub>3</sub> with Ni<sup>2+</sup> ions in a trigonally distorted octahedral ligand field. The electronic absorption spectra of this complex matched that given by Furlani & Morpurgo (1961) and agreed with the structural results (Stucky, D'Agostino & McPherson, 1966).

\* Paper presented at the American Crystallographic Association Winter Meeting, January 25–28, Atlanta, Georgia. This work was supported in part by The Advanced Research Projects Agency under Contract SD-131.